



OTC 11037

## Direct Impedance Heating of Deepwater Flowlines

A.B.Hansen/Thermotite as, T.L. Clasen/Alcatel Kabel Norge AS, R.M. Bass/Shell Oil Products Co.

Copyright 1999, Offshore Technology Conference

This paper was prepared for presentation at the 1999 Offshore Technology Conference held in Houston, Texas, 3-6 May 1999.

This paper was selected for presentation by the OTC Program Committee following review of information contained in an abstract submitted by the author(s). Contents of the paper, as presented, have not been reviewed by the Offshore Technology Conference and are subject to correction by the author(s). The material, as presented, does not necessarily reflect any position of the Offshore Technology Conference or its officers. Electronic reproduction, distribution, or storage of any part of this paper for commercial purposes without the written consent of the Offshore Technology Conference is prohibited. Permission to reproduce in print is restricted to an abstract of not more than 300 words; illustrations may not be copied. The abstract must contain conspicuous acknowledgment of where and by whom the paper was presented.

### Abstract

Direct heating of flowlines to prevent formation of hydrates and wax is becoming an attractive alternative to conventional technology. As the water depths increase in offshore oil and gas exploration world wide, reliable flowlines and risers are extremely important to economically recover these deepwater fields.

Conventional technology relies on enough thermal insulation on the flowline to allow steady state operation outside the hydrate region or to permit sufficiently long cool-down periods for typical shutdown operations

With the advent of severe flow assurance problems, direct heating can solve many of these problems by eliminating or reducing the costly back-up systems required.

This paper examines the details of an ongoing development project funded by the DeepStar program, demonstrating a direct heated system with respect to thermal and electrical performance.

Facts from the completed engineering phase regarding system description, calculation examples, test results and cost comparisons are presented and discussed. Currently, approximately ¼ mile of a thermally insulated flowline with an electrical cable is being field tested in shallow (100 ft.) Norwegian waters. The overall project will be completed in August 1999.

### Introduction

As offshore oil and gas production pushes into deeper water, the risk of hydrate plugging of pipelines and flowlines continues to grow, as does the cost of remediating any such

plugs. Conventional methods of preventing hydrate plugs, such as blowdowns, hot oiling and methanol injection are costly and not entirely reliable. For example, at locations where the subsea manifold is higher than the riser base, or locations where the flowline route has substantial high and low spots to trap gas, the process of venting gas is very complex. Conventional remediation techniques, requiring pressure blowdown, are also uncertain and it may take months to melt a hydrate plug.

Electric heating can be a very attractive alternative for both prevention and remediation of hydrate plugs having potentially high reliability and little adverse operational impact.

Improved reliability of flowlines is also critical in terms of operational costs. Direct heating may improve reliability and substantially reduce operational costs of subsea fields.

Electric heating may also prove effective in preventing or remediating paraffin plugging. In this case it may be possible to reduce capital costs by replacing conventional pigging loops with single heated flowlines.

Two direct heated systems are considered 1) the fully insulated system, requiring complete electrical insulation of the flowline from the seawater, and 2) the earthed current system, requiring electrical communication with the seawater through anodes or other means. For both systems, current is passed directly through the flowline pipe to provide heating.

An earthed current system will be implemented at the Statoil Åsgard field in the North Sea. The system is to be operational from October 2000.

Although direct heating can be applied and operated in several modes, this paper will concentrate on the main task within DeepStar, i.e. the fully insulated (closed) system.

### Performance Requirements

In order to develop a design basis for the direct heating system, the project group developed functional requirements. These requirements were important to establish the work scope of the project and to summarize the objectives. Typical parameters are water depth, U-values, pipe steel grades, and

heating cycles. In general, the functional requirements for a heated flowline system in the Gulf of Mexico are listed in Table 1.

### **System Design and Description**

A fully insulated system is a single-phase system consisting of flowline as forward conductor, and cable or seawater as the return conductor. Both flowline and cable must have sufficient electrical insulation for the applied service voltage.

The system consists of the following main parts:

- Insulated, non-jacketed flowline
- Power cable
- Flowline insulating joint
- Subsea power connector
- Topside equipment

### **Flowline insulation system**

The flowline insulation is basically designed for thermal purposes. During normal operation of the flowlines, the insulation coatings provide sufficient thermal capacity to prevent thermal losses through the steel pipe wall. Dependent on the water depth, the coating system can be tailored to meet specific requirements through the use of solid, foamed or syntactic polypropylene. Typical flowline insulation is given in figure 1.

#### ***Electrical insulation system design***

The basic principle for the fully insulated system to function is that the loop is fully electrically insulated. The thermal insulation also acts as an electrical insulation. Any voids or disbonding in the insulation would be a weak link in the insulation system. Tests indicate that a maximum operating voltage of approximately 20 kV can be used.

### **Cable insulation**

The system voltages to be used for this kind of system will be in a range below 20 kV, depending on flowline lengths. For this voltage rating, a conventional XLPE submarine cable can be used. The cable design represents the state of art technology for wet design submarine cables and is shown in figure 2.

### **Flowline insulating joints**

For the fully insulated system, it is important to insulate the flowline electrically from the surrounding equipment, e.g. subsea templates and wellheads. Physically, a device inserted in the flowline executes the separation. This device separates the flowline and template connection (far end) / platform connection (near end). It is built to withstand the full service voltage between the energized flowline and earthed connection.

The insulating joint is based on a design developed for pipe in pipe systems. This design is shown in figure 3.

An insulating joint for the actual voltage and current range

is under development. This prototype is designed for a service voltage of 15 – 20 kV.

### **Topside equipment**

Topside equipment such as transformers and compensator equipment is available from electrical equipment suppliers.

### **Connectors**

State of the art technology is to perform connections at the surface. However, for ease of installation, it is recommended to use a wet mateable high voltage power connector. This is a specially designed device, which connects cable from platform to cable along flowline.

Wet mateable connectors for the actual voltage and current range are under development and expected to qualify for service during 1999.

### **Corrosion**

A fully insulated system does not need an outer cathodic protection.

With one damage in the coating, there will be a normal corrosion rate for the exposed pipe material. This corrosion rate will depend on the accessibility of the seawater and the size of the exposed area. When the pipes are heated the corrosion rate increases, but it will soon go back to normal corrosion rate as soon as the power is turned off.

With two or more damages in the protection coating, there will be AC current flowing between the two exposed areas. This will result in an increased corrosion rate on the system.

However, damages in the protection coating will be detected at an early stage provided that polarization measurements (PI) are performed on a regular basis. Hence, corrosion due to damages in the coating is not an issue.

The presence of an electrolyte over the insulation in the flowline insulating joint represents a potential current path between the insulated system and the platform/template side. No current will flow in this path (or any parts in contact with the fluid inside the flowline) if the flowline insulating joint is designed correctly. Hence, there will be no internal corrosion.

### **Installation and Protection requirements**

In general, installation of a direct heated flowline system can be performed as a combined installation (cable piggyback to the flowline) or as separate installations. For both options, the use of a wet mateable high voltage power connector is preferred. Use of wet mateable connectors will reduce complexity of operation related to connecting flowline and cable. The preferred installation mode will be determined by the specific project needs.

### **Installation of flowline and cable piggyback**

Cable and flowline installation may occur simultaneously. A clamp will be mounted on the flowline for securing the cable.

Strapping operation will slow the laying operation, and as a general rule, the laying speed will be as below using a reeling vessel:

|  |                |
|--|----------------|
| Laying speed with a piggybacked cable: | 300-400 m/hour |
| Laying speed without cable:            | 500 m/hour     |

### **Installation of separate cable**

Cable installed separately will allow the installation of the cable to take place after the flowline has been installed. This might lead to a lower installation cost, as it is possible to lay the flowline and cable with conventional techniques and speeds. The laying can be performed at different periods of time, increasing the flexibility for the overall vessel logistic and for the field development.

Factors of importance here are total field layout, length and transportation cost for the cable. A combined installation of cables for the electric heating system and umbilical is possible with this installation scenario and should be sought to reduce cost.

### **Protection**

Since the cable is less resistant to impact than the flowline, it is recommended to protect the cable if risk analysis shows risk of damage of the cable. Armor protects the cable against minor impact. In risk areas it is recommended to trench the cable. In general, the water jetting tools are considered the best, as they do not provide a risk of damaging the cable during the jetting process. In addition, the narrow trench will not impose detrimental environment effects.

Commercially available water jetting tools are now operating down to approximately 1000 m (3000 ft.) However, tools for operation at greater depths are being built.

#### ***Connection of cable to flowline and riser***

Two options exist for connecting the cable to the flowline:

Option 1. Perform a cable joint between the main cable and the pigtail connected to the flowline insulating joint.

Option 2. Use wet mateable connectors to connect the main cable to the flowline insulating joint pigtail.

Option 1 requires performing a joint onboard a ship. This is standard procedure for performing repair joints. A cable length, pigtail, will be connected to the flowline insulating joint on the pipe laying vessel. The pigtail length has to be sufficient to accommodate the actual water depth. When the cable vessel arrives, the pigtail has to be lifted to the deck of the cable vessel. Then this cable will be spliced to the cable in the cable-laying vessel, ready to be laid.

By using Wet Mateable High Voltage Power Connectors, a

different approach can be chosen. Then flowline and cable can be installed at different times, and the connection is performed as a conventional pull-in. This type of installation will ease a possible retrieval due to damage of the cable.

### **Operation and maintenance**

A fully insulated system can be operated in three different operation modes:

1. Fully insulated system, cable return AC (see figure 4)
2. Fully insulated system, cable return DC (see figure 4)
3. Fully insulated system, seawater return AC (see figure 5)

The heating system is basically designed for use during planned and unplanned shutdown. To check the integrity of the system, it is proposed to perform polarization measurements (PI) on a regular basis. Polarization measurements are expected to show leakage current for the circuit. The circuit is energized with DC. When the insulation is intact, a current corresponding to the voltage and conductivity of the insulation will be measured. If damage(s) of the flowline insulation resulting in insulating failures have occurred, the measured current will be much higher. This method will be further tested during the field test.

The effect of a direct heating system on adjacent systems will be small. Due to the current in the cable and the pipe an electrical field will be set up around the cable and the pipe. As a guideline, a distance of 5m (15 ft.) to adjacent structures should be sufficient.

### **Calculation examples**

The calculations have been performed in cooperation with SINTEF Energy Research.

The electrical circuit that is used to model the heating system can be represented as a  $\pi$ -equivalent, as shown in figure 6. The total impedance,  $Z$ , is then the sum of  $Z$  for the insulated flowline, and  $Z$  for the return cable. A computer model is then utilized.

For the calculation example a flowline size of 8" is used. Calculations are performed for a flowline length of 15 miles (24 km). This is a typical flowline for the deep water Gulf of Mexico (GoM) fields.

When judging the system, there are 3 factors of importance, voltage, current and power. Assuming that the platform power supply delivers a voltage of 13,8 kV, a transformer is needed to transform the voltage up or down to the voltage required for the heating system. The voltage in the sending end and the load gives the current.

The cable can either be placed piggyback on the flowline, or laid in a separate corridor. The calculations are based on a distance between cable and flowline of 1m. A larger distance

will increase the impedance.

The results from the calculations are given in Table 2.

### **Sensitivity analysis**

A number of calculations have been performed in order to investigate the sensitivity of different parameters. The following parameters have been investigated:

- The effect of spacing between cable and flowline
- The effect of steel wire armor vs. non metallic armor
- The effect of cable conductor size
- The effect of burial of the flowline and cable

#### ***Spacing Between Flowline and Cable***

Calculations have been performed with piggyback, 1m spacing and 100 m spacing. As can be seen from figure 7 the voltage demand increases as the spacing between cable and flowline increases. From figure 8 it can be seen that the power demand is highest when the spacing is 100m. The power required for 1m (3 ft.) spacing and piggyback is almost the same.

#### ***Steel Wire Armor versus Non Metallic Armor***

As seen from figure 9, a non-metallic armored cable will result in the lowest voltage demand for a 100m (300 ft.) spacing between cable and flowline. For a shorter spacing, the result will be the opposite, giving a 10 – 15 % lower voltage demand for a metallic armored cable.

#### ***Cable Conductor Size***

The effect of conductor size has been calculated for steel wire armored cable and 100 m spacing between flowline and cable. Two cross sections were considered 630 mm<sup>2</sup> and 1000 mm<sup>2</sup>. Only small differences were noted. This implies that the conductor cross section can be chosen according to the normal dimensioning criteria for power cables.

#### ***Burial of Flowline and Cable***

If the flowline is buried, the power needed for heating will be reduced. Calculations have been performed for a burial depth of 1m. A specific thermal resistivity of 0.5 Km/W is used for the sea bottom soil properties. The necessary heat development will then be 66 W/m compared with 117 W/m for the unburied case. Calculations have been performed with steel wire armored cable, and 100 m spacing. The results are shown in figure 10.

### **Test program**

The project group developed a three-stage extensive test program consisting of the following parts:

1. Laboratory tests to establish baseline mechanical and electrical properties for the coating and pipe material
2. Field test of ¼ mile long section to establish performance and verify engineering design
3. Post-tests on retrieved field test length to verify the electrical integrity of the flowline insulation after thermal and mechanical exposure.

### **Laboratory tests**

Extensive laboratory tests were part of the phase I scope of work. Laboratory tests comprised analysis of the pipe material and the flowline insulation, as well as electrical testing of full-scale insulated pipes and field joints.

#### ***Tests on insulating material***

The thermal insulated pipe will be used as a high voltage cable, where the steel pipe is the conductor, and the thermal insulation is also the electrical insulation. A flowline section with a typical coating design was produced and tested to establish mechanical properties and electric properties.

Each material in the multiple layer polypropylene (PP) has been tested, both virgin and aged materials. The initial tests indicate that PP seems to be well qualified for the high voltage electrical stress in a heated flowline system.

#### ***Measurements of electrical properties of flowline material***

The impedance and the heat development are dependent on the magnetic properties and the resistivity of the steel pipe. Measurements performed indicate that mechanical stress and heat treatment can have substantial effect on the relative permeability of the steel.

#### ***Laboratory tests on full scale insulated pipe joints***

Laboratory tests are performed on insulated pipes and field joints in order to qualify the use of PP as an electrical insulation material. The tests are performed according to international standards for cables. The initial tests indicate that the voltage of approx. 20 kV can be regarded as a maximum system voltage for use at this particular pipe dimension and insulation thickness. Typical service voltages for the GoM are in the range from 15 – 20 kilovolts.

#### ***Field test***

A test sample of 380m coated flowline is installed at the test site in Halden, Norway. The test sample contains 32 field joints, one for every 12 meters. The joints were made at the test site in Halden according to standard field procedures. A flowline insulation joint is connected to one end of the pipe. The entire test sample is installed at a maximum water depth of 30 meters. The field test installation is shown in figure 11.

The field testing involves ten heating cycles in four different operation modes. The test program consists of ten cycles in each operation mode. The four operation modes are:

- Fully insulated system, AC
- Fully insulated system, seawater return
- Fully insulated system, DC
- Earthed current system, AC.

The initial tests verify that the engineering calculations with respect to heat dissipation and temperature rise are correct.

The obtained data are analyzed and will be used as part of developing an engineering design tool for direct heating systems. Figure 12 shows the temperature in the steel pipe during one heating cycle.

#### **Post-tests on retrieved field test pipe length**

After heat cycling in different operation modes, the field test length will be retrieved and the flowline cut in suitable lengths for laboratory testing. The laboratory testing comprises:

- Bending test
- Material evaluation after bending test
- Electrical test after bending test

#### ***Bending tests***

Reeling is likely to be the preferred installation mode and the project group is going to simulate worst case reeling scenario with 6 reverse bending cycles at 2.5% total strain in the outer diameter of the steel pipe. This corresponds to a bending radius of 3.4m. for the 6" OD flowline section.

#### ***Material evaluation***

After the simulated reeling tests, the coating system will undergo subsequent property tests to investigate if reeling has an effect on mechanical properties.

#### ***Electrical tests***

These tests will be performed on pipe samples including field joints after the bending test, and will give valuable information regarding the condition of the pipe insulation after long term tests and mechanical handling tests.

#### **Cost comparison study**

In order to establish some figures regarding the competitiveness of direct heating systems, the project completed a cost comparison study based on the functional requirements (see Table 1) and the dimensioning factors as described in this paper. The cost comparison investigated pipe-in-pipe (PIP) as the existing technology base and used the directly heated alternatives for comparisons.

The items included for the direct heated systems are cable, pipe and coating, installation, topside equipment and other items. Wet mateable connectors are used for the alternatives. The cost comparison looks at a typical GoM flowline for deep-

water applications, i.e. 8" OD X65 steel pipe with a U-value of 0.88 BTU/ft<sup>2</sup> hr °F (5.0 w/m<sup>2</sup> °K). Cost comparison data are shown in table 3.

#### **Conclusions and Recommendations**

Based on the performed work and results from the ongoing field test, the conclusions and recommendations are:

1. Maximum step-out lengths will be available with the smallest pipe diameter and highest insulation thickness
2. The general GoM case used (8"/15 miles) shows power requirements for the fully insulated system within existing power availability at host platforms
3. Existing installation methods and laying ships can be used
4. Polypropylene used for thermal insulation seems well qualified for electric stress imposed during heating cycling
5. Cost comparisons show a 30% reduction in investment cost compared to Pipe-in-Pipe (PIP)
6. More work is needed regarding the flowline insulating joint, in-situ repair methods, procedures, and on risk aspects to reveal probable damage scenarios.

#### **Acknowledgements**

The authors would like to thank the management of Thermotite AS, Alcatel Kabel Norge, Shell Oil Products Co. and the DeepStar program for permission to publish this paper.

Special acknowledgements are given to Carl G. Langner and to other companies and individuals for their contribution to the project.

#### **References**

1. Bass, R.M.: and Langner, C.G.: "Direct Electric Heating of Pipelines", Deep Offshore Technology D.O.T, New Orleans 17-19 November 1998.
2. Aarseth, F.: "Use of Electrical Power in Control of Wax and Hydrates, OTC 8541, Offshore Technology Conference, Houston, TX, May 1997.

| TABLE 1-DESIGN PARAMETERS FOR GoM                 |                              |                           |
|---|------------------------------|---------------------------|
| DESIGN PARAMETER                                  | VALUE                        | VALUE (SI units)          |
| Water depth                                       | 10 000 ft                    | 3000 m                    |
| Ambient sea water temperature                     | 28°F                         | - 2°C                     |
| Seawater conductivity                             | 3.5 $\Omega\text{m}^{-1}$    | 3.5 $\Omega\text{m}^{-1}$ |
| Pipe nominal O.D.                                 | 4" - 12"                     | 100 - 350 mm              |
| Steel Grade                                       | X65                          | X65                       |
| Max strain in steel pipe (installation reel)      | 2.5%                         | 2.5%                      |
| Overall Heat Transfer coefficient (OHTC, U-value) | 0.88 BTU/ft <sup>2</sup> h°F | 5 W/m <sup>2</sup> K      |
| Design temperature                                | 284 °F                       | 140°C                     |
| Temperature rise                                  | 60°F/72h                     | 33°C/72h                  |
| Max. Voltage during operation, U <sub>0</sub>     | 14.4 kV                      | 14.4 kV                   |
| Operating frequency                               | 60 Hz                        | 60 Hz                     |
| Max. expected current rating, closed system       | 1000 - 1500 A                | 1000 - 1500 A             |
| Max. expected current rating, open system         | 1200 - 2000 A                | 1200 - 2000 A             |
| Design life                                       | 20 years                     | 20 years                  |

| TABLE 2-CALCULATIONS STEEL WIRE ARMORED CABLE     |                          |       |
|---|--------------------------|-------|
|   | 15 miles (24km), 8" pipe |       |
| Current at input, I, [A]                          |                          | 560   |
| Terminal Voltage, U, [kV]                         |                          | 13    |
| Power requirements                                | P [MW]                   | 3.4   |
|   | Q [MVA]                  | 6.2   |
|   | S [MVA]                  | 7.1   |
| Ratio between current at the input and at the end |                          | 0.98  |
| Conductor cross section [mm <sup>2</sup> ]        |                          | 630   |
| Cable rated voltage, U <sub>0</sub> /U [kV]       |                          | 14/24 |

| TABLE 3-COST COMPARISONS* |     |   |
|---------------------------|-----|---|
| System                    | PIP | Electric heating insulated using AC and steel armored cable |
| Distance                  |     |   |
| 6,2 Mile                  | 6,2 | 3,6   |
| 15 Mile                   | 15  | 7,95  |

\*) All Cost items in MM\$

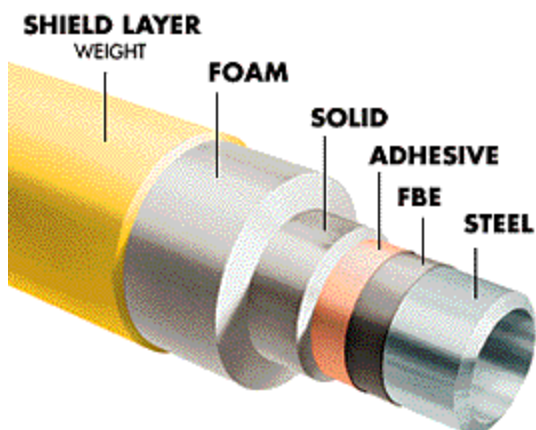

Figure 1-Flowline with polypropylene multi-layer insulation

| No. | Description                            |
|-----|--|
| 1   | CONDUCTOR, TINNED COPPER WIRES         |
| 2   | CONDUCTOR SCREEN, SEMICONDUCTING XLPE  |
| 3   | INSULATION XLPE                        |
| 4   | INSULATION SCREEN, SEMICONDUCTING XLPE |
| 5   | LEAD SHEATH                            |
| 6   | BEDDING TAPES                          |
| 7   | ARMOUR                                 |
| 8   | BEDDING TAPES                          |
| 9   | OUTER SHEATH                           |

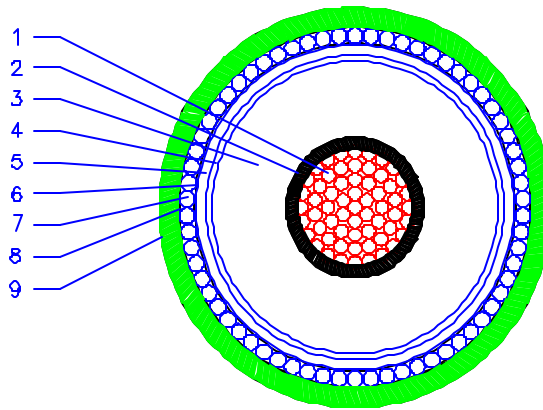

Figure 2-Typical XLPE power cable crossection

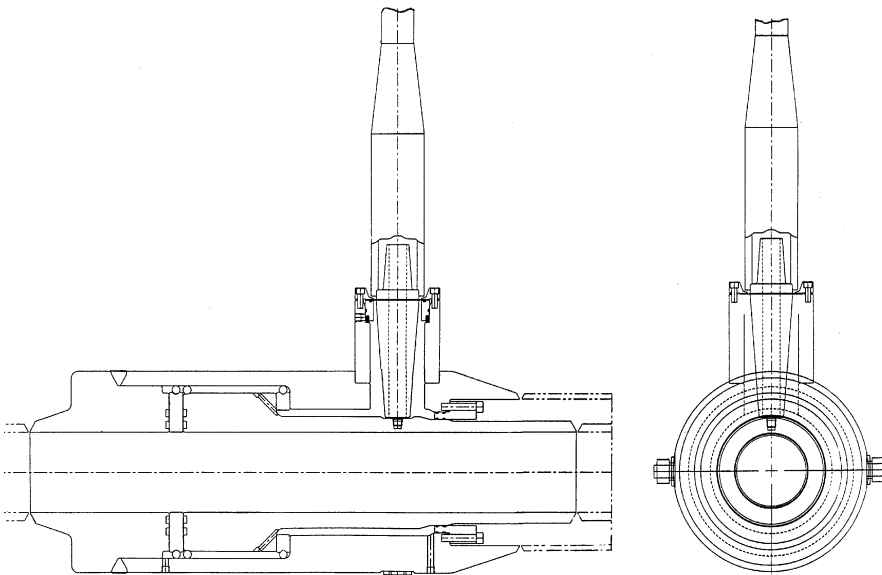

Figure 3 Flowline insulating joint

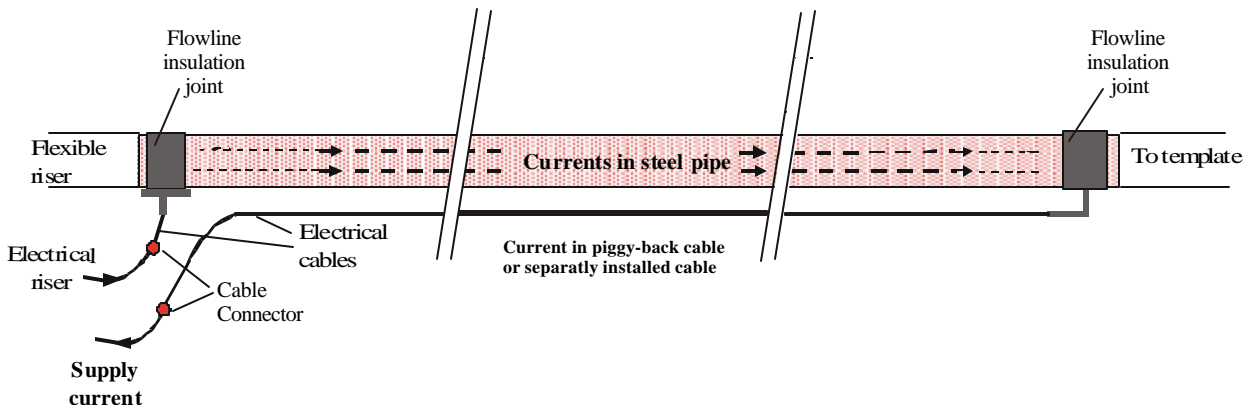
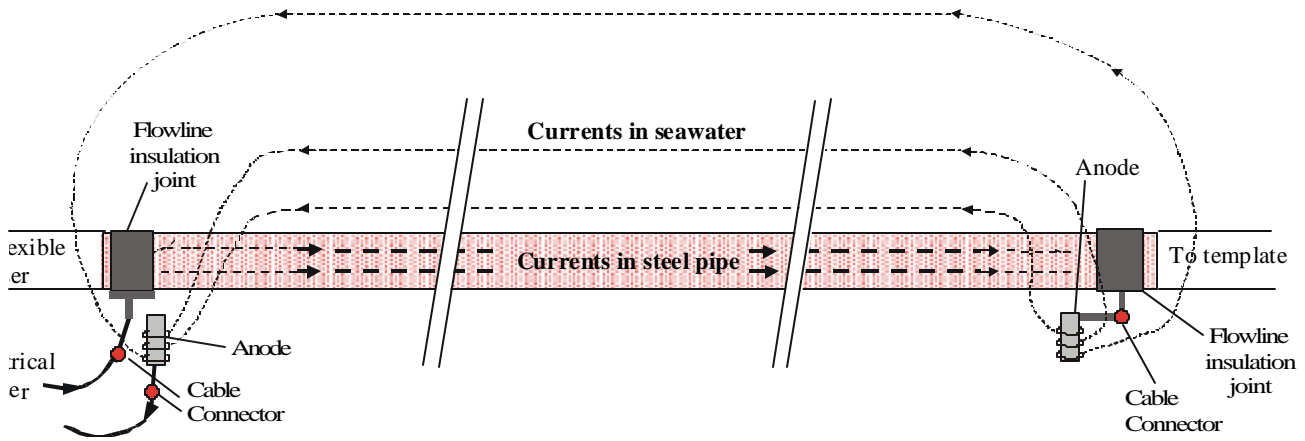

Figure 4 Circuit with cable return



Supply current

Figure 5 Circuit with seawater return

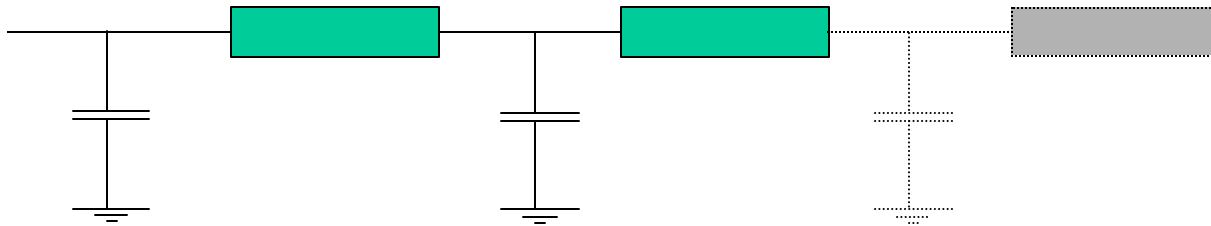

Figure 6-Equivalent p circuit

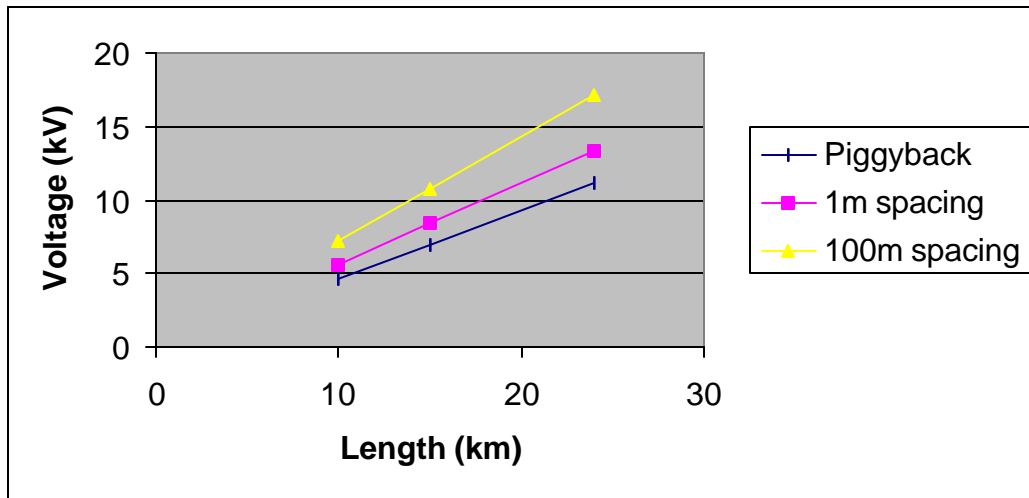

Figure 7 Voltage as function of length

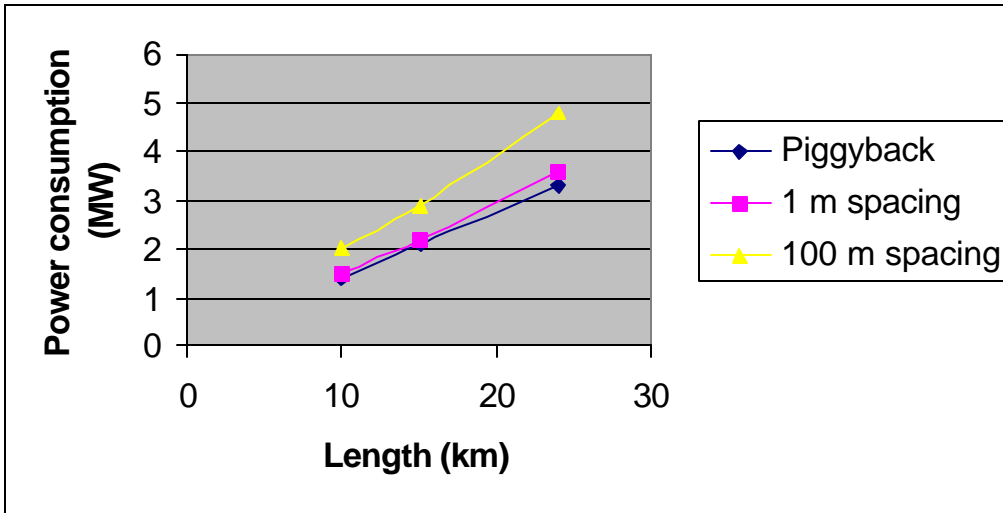

Figure 8-Power consumption as a function of length

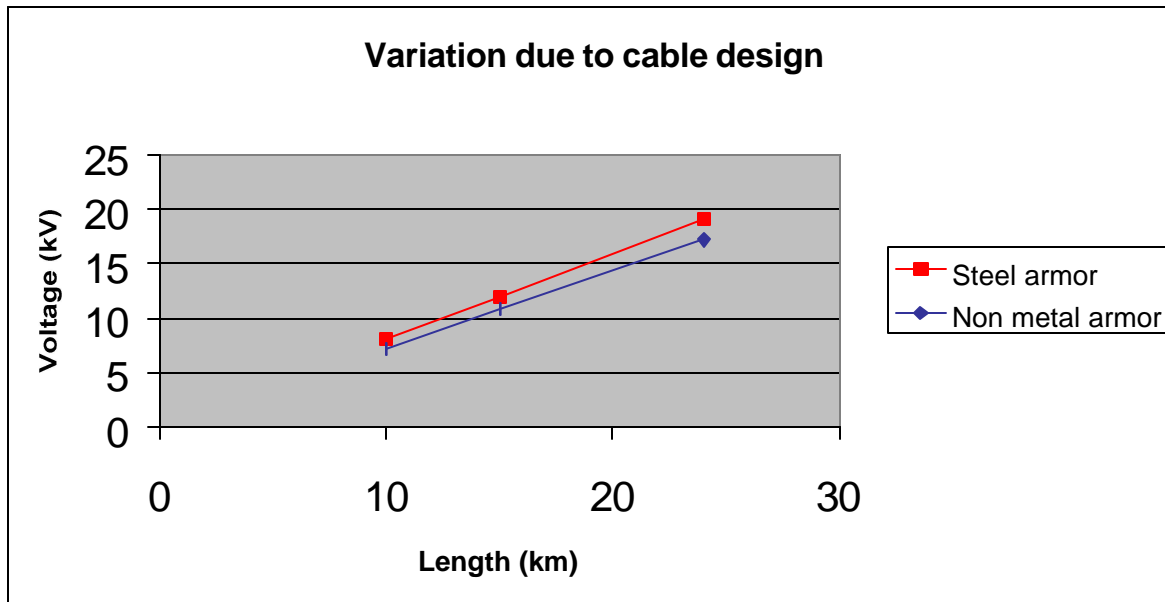

Figure 9-Voltage variation due to cable design, 100m spacing

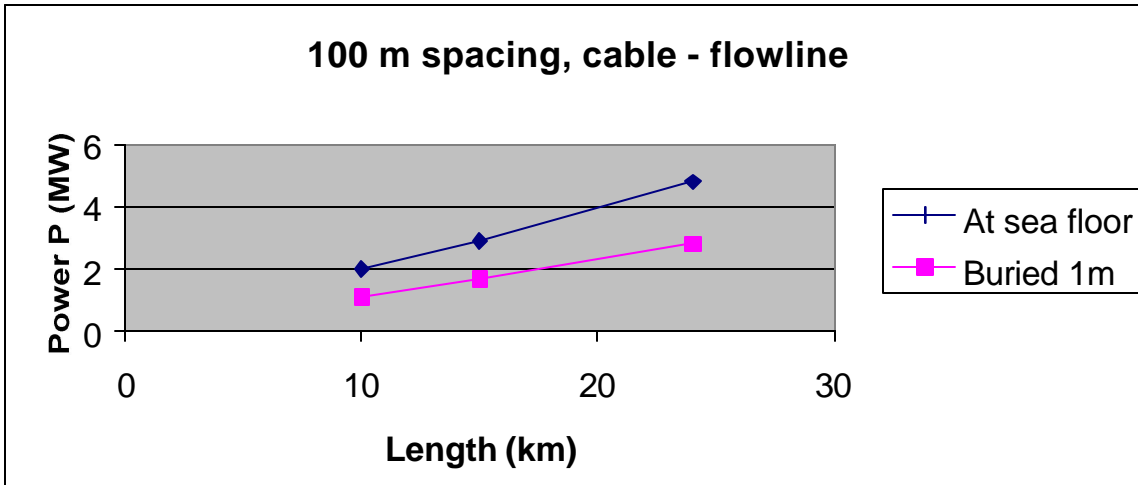

Figure 10-Power as function of length, buried and not buried



Figure11-Installation of field test flowline section (380m long)

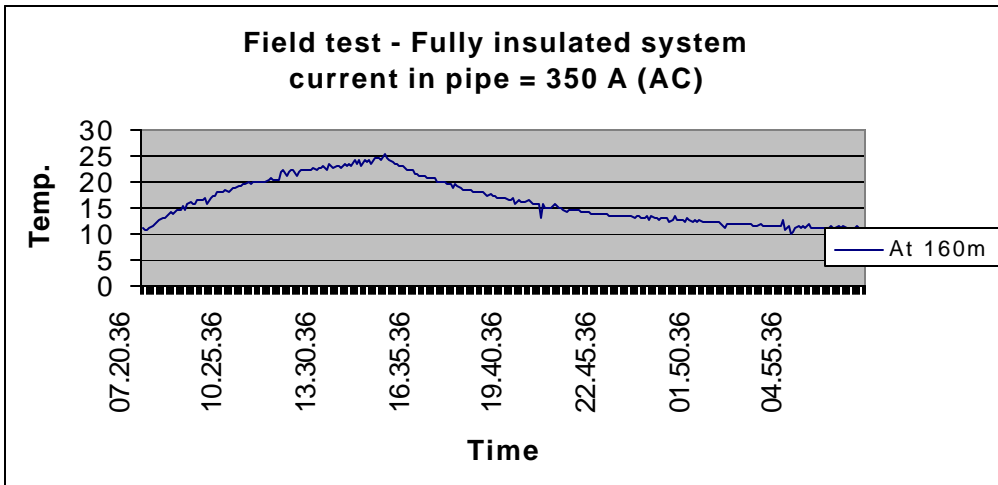

Figure 12-The temperature is measured at several positions along the flowline, on the inner diameter of the pipe. This diagram shows the temperature 160 m from land, during one heating cycle.