

AE

Asphalt Enamel Pipeline Coating

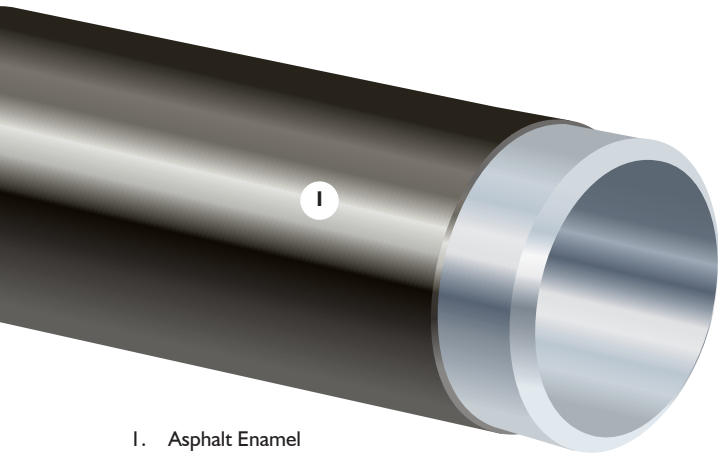

PRODUCT DATA SHEET



I. Asphalt Enamel

Product Description

Bredero Shaw is the world's leading provider of Asphalt Enamel (AE) coatings. **AE is a plant applied durable coating based on modified bitumen (asphalt) that has been successfully used for many years for corrosion protection of steel pipes.**

Applications



Oil & Gas Transmission and Distribution Pipelines



Small Diameter Pipelines



Large Diameter Pipelines

Related Standards and Specifications

- GAZ de France R 01
- EN 10300
- Shell DEP 31.40.30.33
- DNV RP-F-106
- BS 4147
- ISO 9001:2008

For additional standards and specifications with which this product complies, please contact your Bredero Shaw representative.



Long Term Corrosion Protection

- Excellent adhesion to steel provides a track record of long term corrosion resistance.
- Recommended for pipelines designed to convey water, gas, oil or any other fluid when the continuous temperature of the fluid being transported does not exceed 70°C (158°F)*.
- AE is a safer and more environmentally friendly system than coal tar enamel.

Engineered Solutions

- Advanced manufacturing techniques allow Bredero Shaw to supply AE coatings with varying grades of asphalt enamels and inner and outer wraps along with a thickness as per your design specification.
- The system can be applied to various pipe diameters from 90 mm (3.5") to over 1200 mm (48").

Proven Performance

- Extensive track record of excellent performance in over 8,000 enamel pipe coating projects
- More than 80,000 kms (49,710 miles) of enamel coated pipe across the world.
- Proven coating technology for use with Concrete Weight Coatings.

Global Availability

- Global network of coating plants minimizes pipe transportation costs
- AE coating for large projects can be performed at multiple Bredero Shaw locations to improve logistics.
- High capacity within the Bredero Shaw plant network allows the client to benefit from single source advantages, ultimately providing more cost effective management of pipe coating needs.

* Actual temperature will depend upon design criteria

Features & Benefits

Asphalt Enamel Pipeline Coating

Typical Plant Capabilities and Product Properties

Capability/Property	AE
Minimum Pipe Diameter	90 mm (3.5")
Maximum Pipe Diameter	1220 mm + (48"+)
Minimum Pipe Length	5.5 m (18')
Maximum Pipe Length.....	18 m (59')
Minimum Recommended Operating Temperature	-40°C (-40°F)
Maximum Recommended Operating Temperature	70°C (158°F)*

Values shown are typical and may vary from plant to plant. Consult Bredero Shaw for special requirements.
* Actual temperature will depend upon design criteria.



AE_rev021

Product Application Process

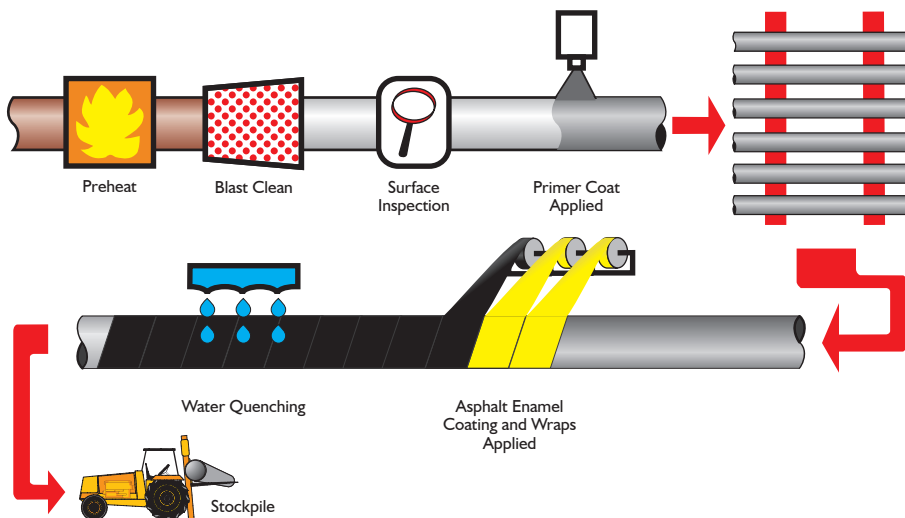

Plants

EMAR
Leith, Scotland

Asia Pacific
Kuantan, Malaysia
Kabil, Batam Island, Indonesia

About Bredero Shaw

Bredero Shaw is the global leader in pipe coating solutions. With more than 80 years of experience, the largest team of dedicated pipe coating professionals, the most extensive network of strategically located plants worldwide and with proven innovative coating technologies, the company has protected more pipelines in virtually every environment and operating condition than anyone in the industry.

Bredero Shaw offers technologically advanced solutions for anti-corrosion coatings, protective and weight coatings, thermal flow assurance coatings, internal coatings, custom coatings and field joints for both onshore and offshore applications. This broad range of products and services provides Bredero Shaw with the unique capability to service the full spectrum of pipeline protection and flow assurance requirements. Consult your Bredero Shaw representative for your unique project requirements.

HEAD OFFICE & AMERICAS
Bredero Shaw
3838 N. Sam Houston Pkwy E.
Suite 300
Houston, Texas
77032-3400, USA
Phone: +1-281-886-2350
solutions@brederoshaw.com

**EUROPE, MIDDLE EAST,
AFRICA & RUSSIA**
Bredero Shaw
Lakeside House
1 Furzeground Way
Stockley Park, Uxbridge
UB11 1BD, United Kingdom
Phone: +44-208-622-3071
EMAR@brederoshaw.com

ASIA PACIFIC
Bredero Shaw
101 Thomson Road
#17-01/02 United Square
Singapore 307591
Phone: +65-6732-2355
asiapacific@brederoshaw.com

Regional Offices